

A

B

C

D

K

MARK	REVISER	DESCRITRN	DATE

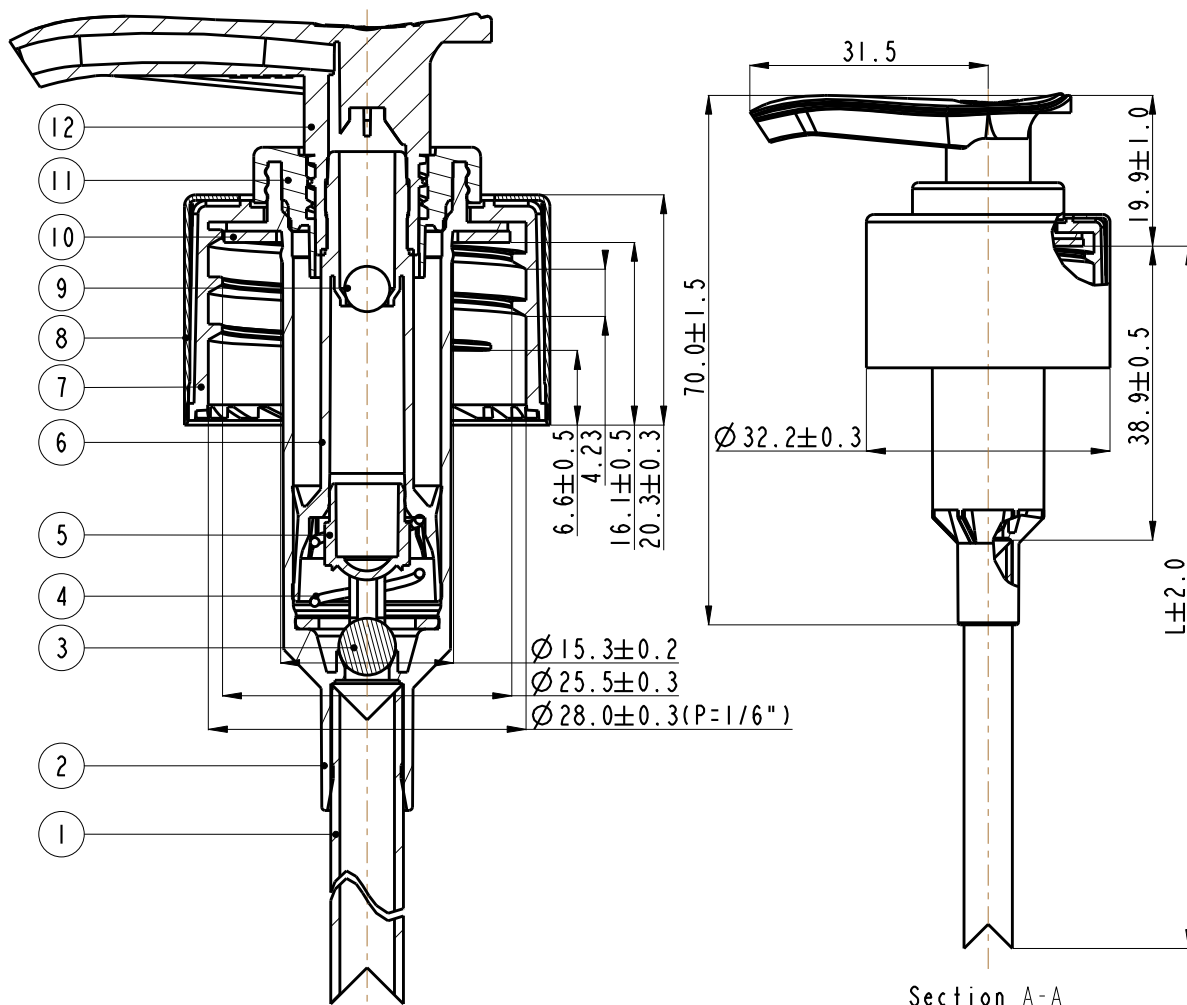

Section A-A

Section A-A
Scale 1.000

No.	Component	Material	Specification	Part No.	QTY	Remark
12	Nozzle	PP	Color for order form	300030108001	1	
11	Connect	PP	Color for order form	300030106001	1	
10	Gasket	PE	$\varnothing 25.2 * \varnothing 14.6 * 1.0 \text{mm}$	300030198002	1	
9	Glass Ball	Glass	$\varnothing 4.0 \text{mm}$	300010197001	1	
8	ALU.Closure	AL	M28/410	300030193002	1	
7	Closure	PP	M28/410	300030105004	1	
6	Piston	PE	Color for order form	300030103001	1	
5	Seal Socket	PP	Natural	300030118001	1	
4	Spring	304H	$\varnothing 10.0 * 35.3 \text{L} * \varnothing 0.8 * 7.5 \text{circle}$	300030196001	1	
3	Glass Ball	Glass	$\varnothing 5.0 \text{mm}$	300030197001	1	
2	Housing	PP	$\varnothing 28$	300030101002	1	
1	Dip Tube	LDPE	$\varnothing 6.4 * 0.80 \text{thickness}$	300030195003	1	

TOLERANCE			\varnothing
0mm-15mm	± 0.05	± 0.10	± 0.50
15mm-30mm	± 0.05	± 0.15	± 1.00
30mm-50mm	± 0.10	± 0.20	± 1.50
50mm-99mm	± 0.15	± 0.30	± 2.00
ABOVE 99mm	± 0.20	± 0.40	± 2.50
CENTER	± 0.10	± 0.50	± 1.00
ANGLER	$\pm 0.25^\circ$	$\pm 0.50^\circ$	$\pm 2.00^\circ$

APPROVED:

UNIT: mm



1

CENSOR:

MODEL NAME:

TITLE:

00301

301A-28/410 Assemble

CHECKED:

SCALE:

VISUAL ANGLE

Q'TY:

REV:

3:2



1/1

A0

DRAFTER: 诸徐煊

PART NO.

FILE NO.

2018/10/16

100030100045

D-LMI277

A

B

C

D