

REVISIONS				
REV.	COR/DR/ECN #	DESCRIPTION	DATE	APPROVED
1	ECN#1516	RELEASE FOR PRODUCTION CHANGED .510±.003 TO .510±.003-.005 IN SECTION A-A	7/27/2011	<i>ayk</i>
2	ECN#1573	ADDED SHEET 2 ADDED COLORANT/ADDITIVE SPECIFICATION CHART TO SHEET 2 ADDED PART NUMBER CAPS0030 PART NAME 18mm NATURAL MATTE SNAP FLIP TOP CAP WITH EARTH E INSERT TO CHART ON SHEET 1 ADDED SECTION B-B TO SHEET 1 ADDED DETAIL C TO SHEET 1	12/6/2011	<i>ayk</i>
2-01	DR#2207	ADDED .69 DIMENSION TO SECTION A-A TO ID OF SKIRT	2/3/2012	<i>ayk</i>
2-02	ECN# 1997	ADDED NEW PART NUMBER CAPS0069 TO SHEET 2 OF 2. 18mm BLACK SNAP FLIP TOP COP W/PLAIN INSERT - .	5/13/2014	

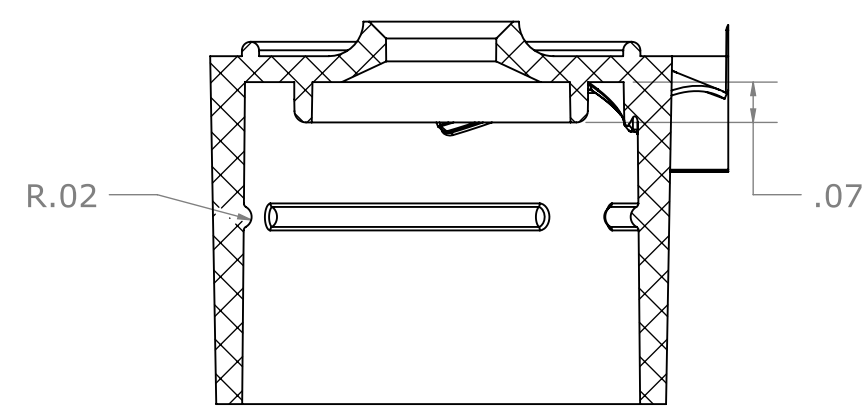

SECTION B-B
SCALE 3 : 1

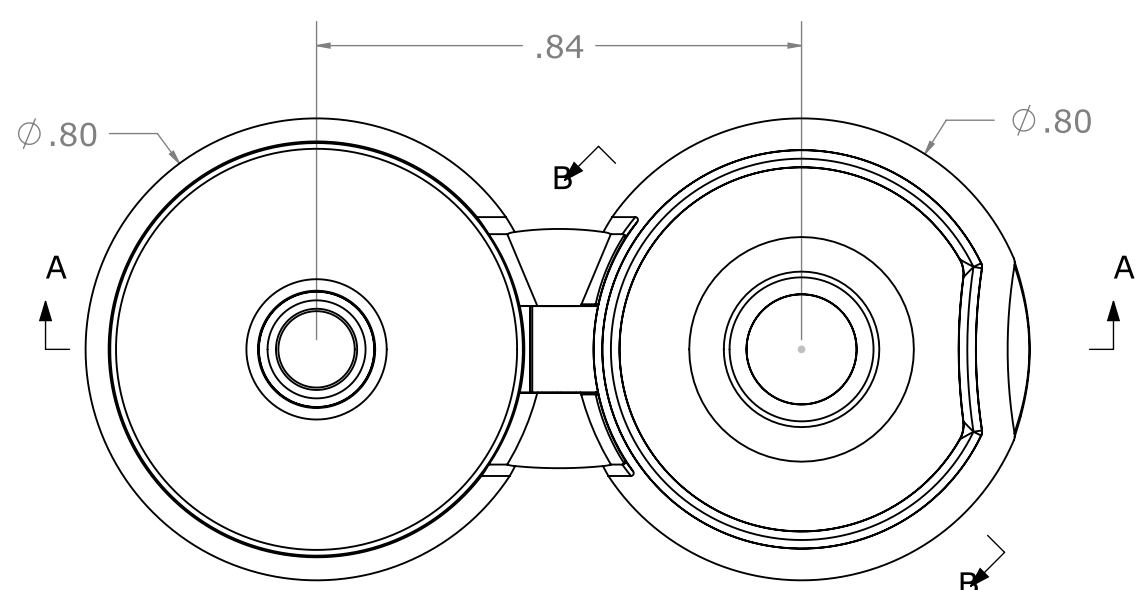
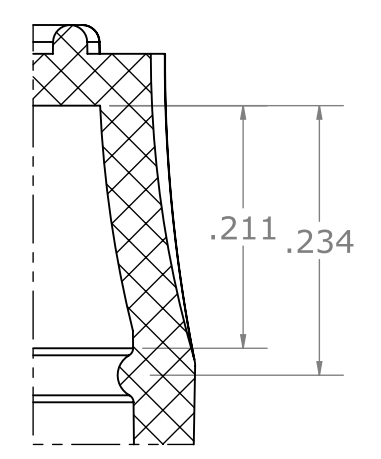
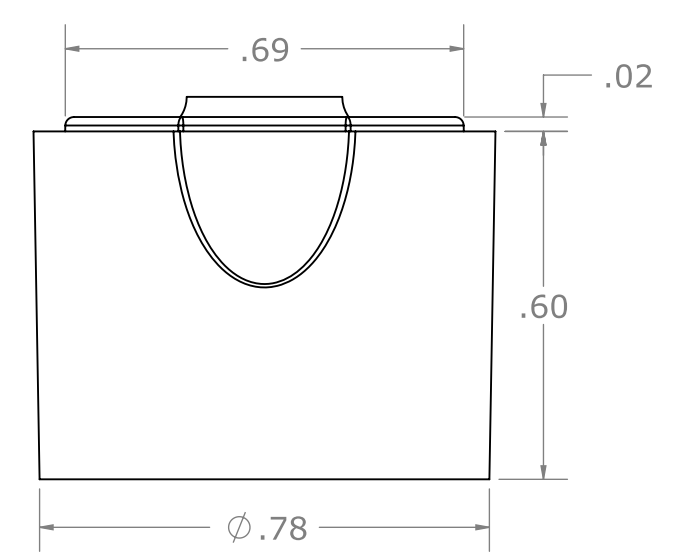
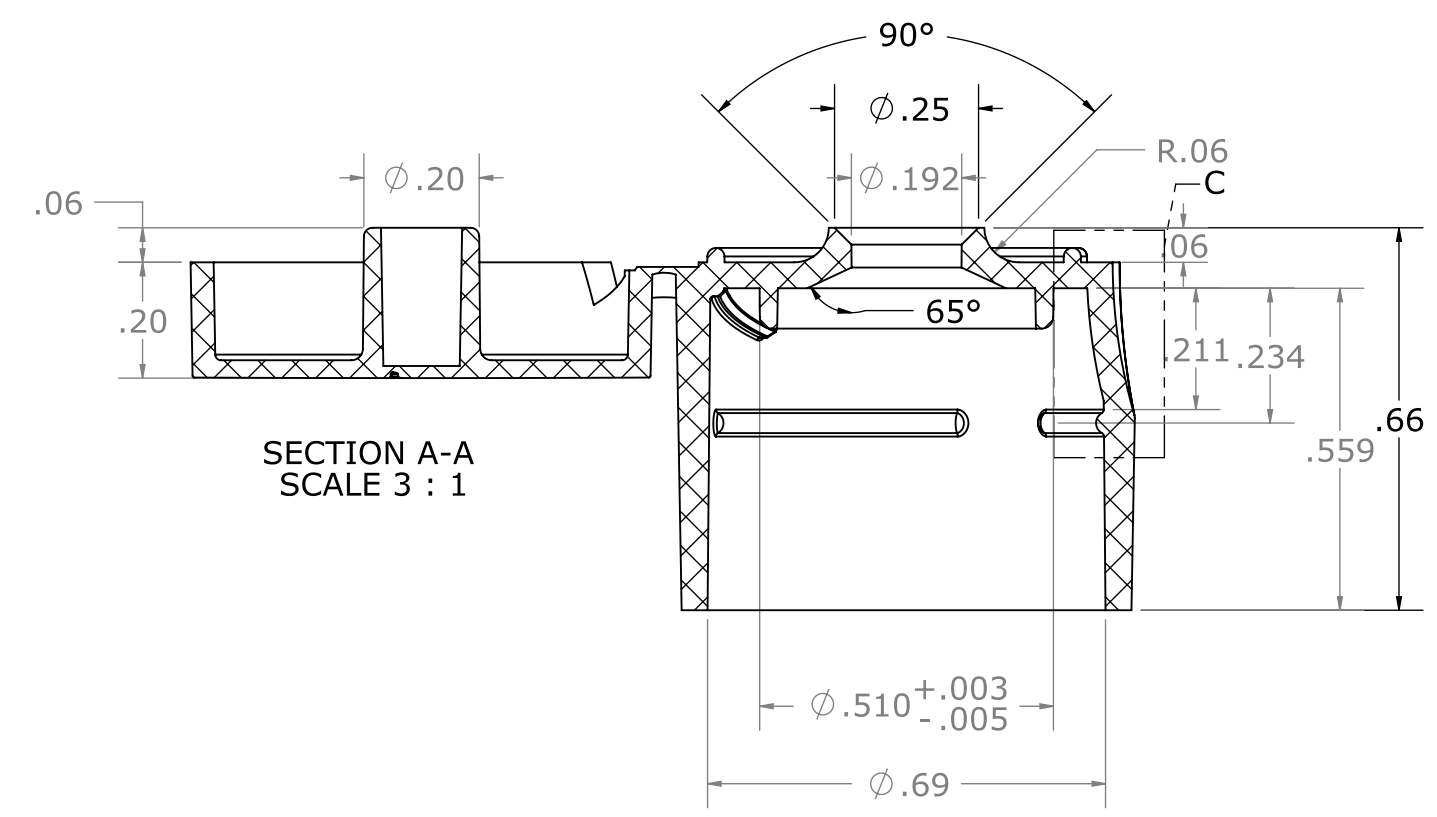
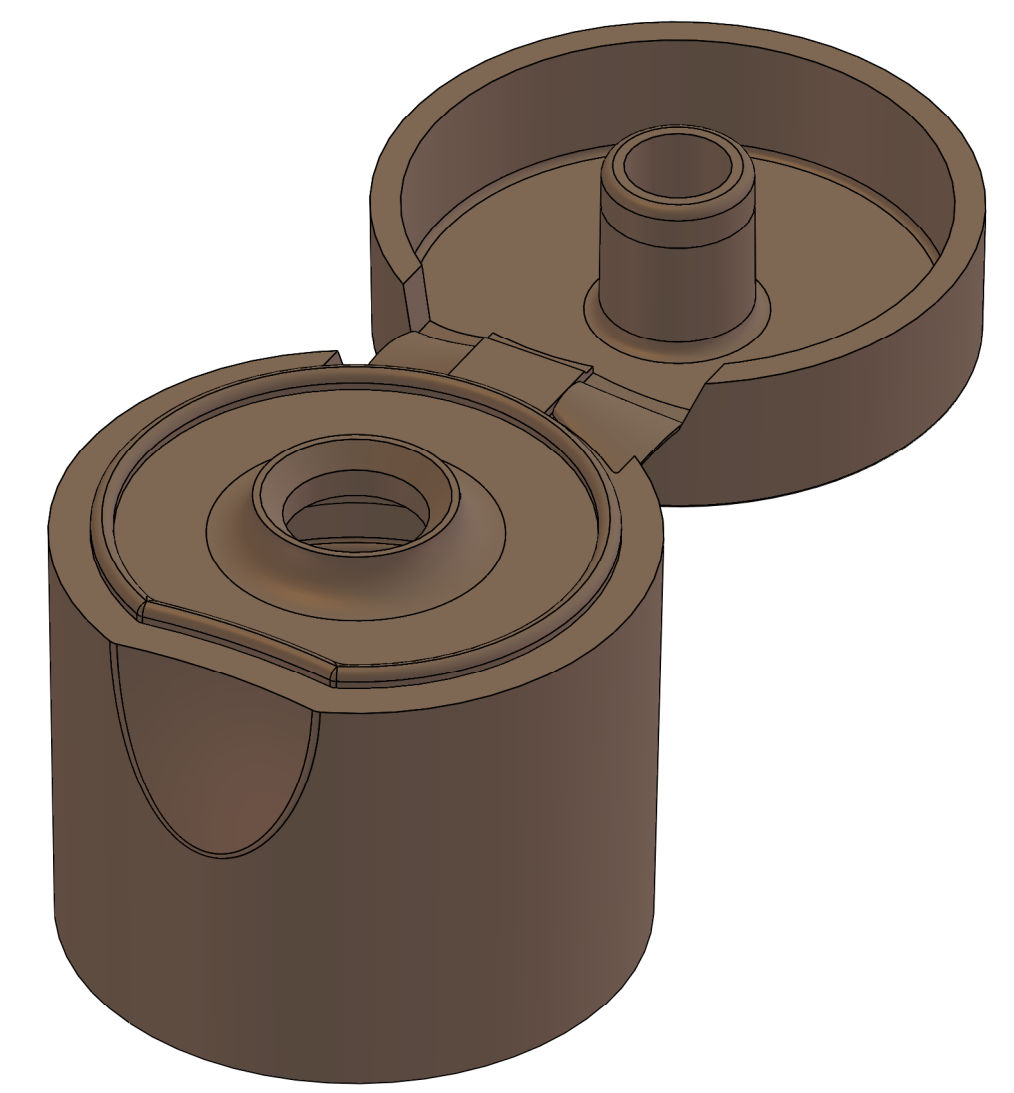

DETAIL C
SCALE 6 : 1

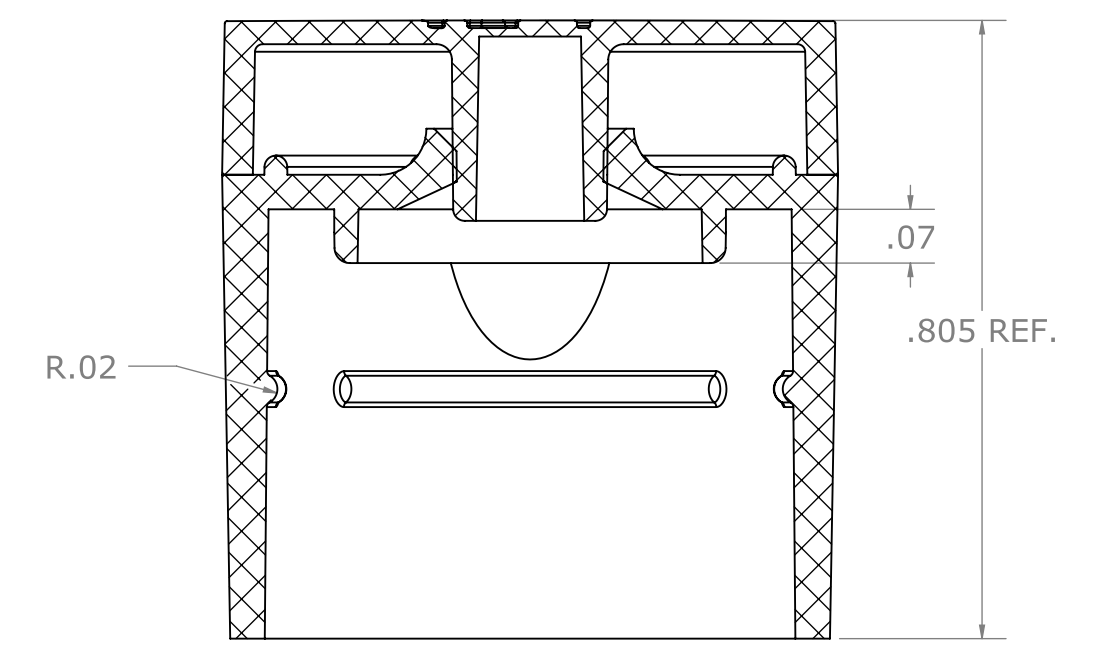

SECTION B-B

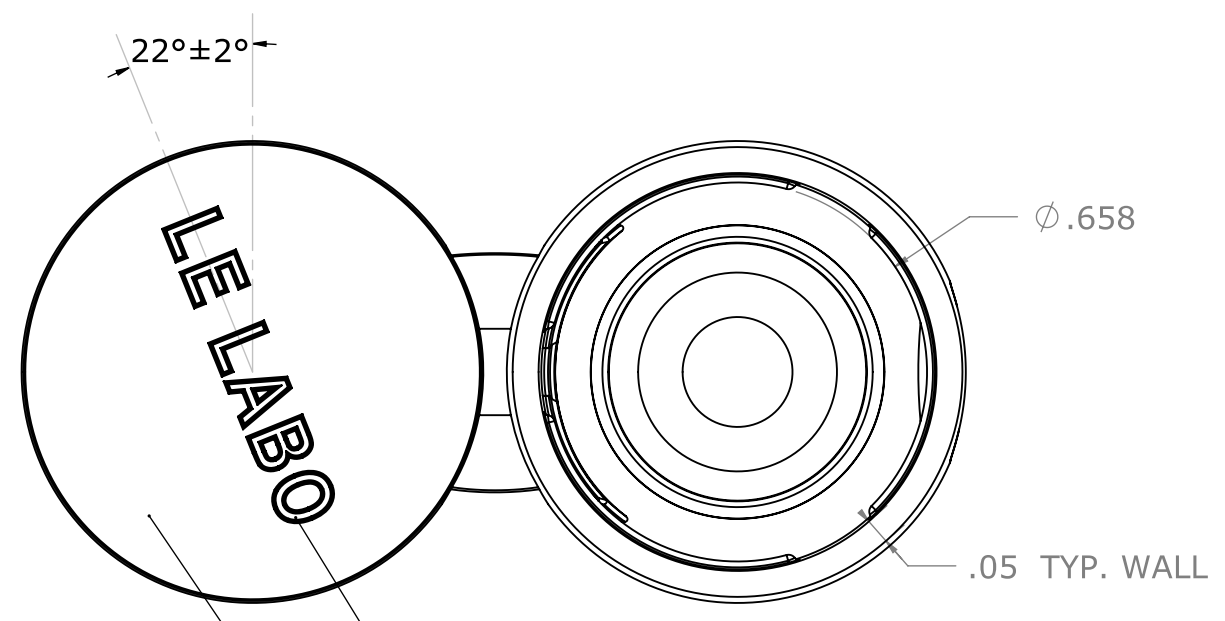

GRAPHIC - POLISH SURFACE
ALL EXTERIOR SURFACES - MATTE FINISH

HINGE SIDE OF CAP

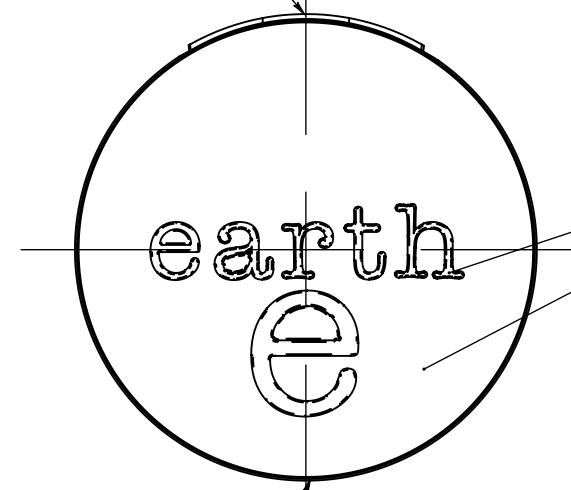



GRAPHIC - POLISH SURFACE
ALL EXTERIOR SURFACES - MATTE FINISH

THUMB LIFT TAB SIDE OF CAP

Product Design to be approved by customer before mold cavities are machined.		CUSTOMER NAME:	
ALL DIMENSIONS ARE IN INCHES TOLERANCE: FRACTIONAL: ± 1/32 ANGULAR: ± 1° TWO PLACE DECIMAL: .01 THREE PLACE DECIMAL: .005 UNLESS OTHERWISE SPECIFIED		PART NAME SEE CHART SHEET 2	
ANY CHANGES TO THIS DRAWING SHOULD BE MADE TO THE PART MODEL SO THAT THE CHANGES ARE MADE PARAMETRICALLY		APPROVALS	
THE INFORMATION ON THIS DRAWING IS CONFIDENTIAL AND IS THE SOLE PROPERTY OF CURRIER PLASTICS. NEITHER THIS DOCUMENT, NOR ANY INFORMATION DISCLOSED HEREIN SHALL BE REPRODUCED OR TRANSFERRED TO OTHER DOCUMENTS OR TO BE USED FOR MANUFACTURING PURPOSES OR DISCLOSED TO OTHERS FOR ANY PURPOSE EXCEPT AS SPECIFICALLY AUTHORIZED IN WRITING BY CURRIER PLASTICS		DESIGNED & DETAILED BY:	DATE
CAD REFERENCE #	IM0121	VP OF N.P.D.	
LIFECYCLE:	RELEASE FOR PRODUCTION	PROJECT ENG MGR	
		QA MGR	
		PART # SEE CHART SHEET 2	
		PROCESS: IM	
		WEIGHT: 1.8grams	
		MATERIAL: PP	
		CUSTOM DESIGN / INJECTION MOLDING / BLOW MOLDING	
		CURRIER PLASTICS V ²	
		SHEET SIZE C	VIEW SCALE 1:1
		SHEET 1 OF 2	
		REV. 2-02	

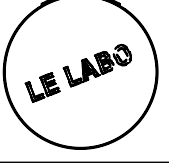
2-02

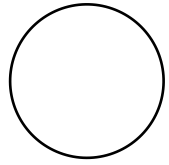
COLORANT/ADDITIVE SPECIFICATION CHART				
PART NAME	PART NUMBER	COLORANT OR ADDITIVE	COLORANT/ADDITIVE NUMBER	DECAL DESIGN
18mm BLACK MATTE SNAP FLIP TOP CAP WITH LE LABO INSERT	CAPS0002	BLACK	1-4454-13	
18mm NATURAL MATTE SNAP FLIP TOP CAP WITH EARTH E INSERT	CAPS0030	NATURAL	----	
18mm BLACK MATTE SNAP FLIP TOP CAP W/PLAIN INSERT	CAPS0069	BLACK	1-4454-13	

Product Design to be approved by customer before mold cavities are machined.		CUSTOMER NAME:	
ALL DIMENSIONS ARE IN INCHES TOLERANCE: FRACTIONAL: $\pm 1/32$ ANGULAR: $\pm 1^\circ$ TWO PLACE DECIMAL: .01 THREE PLACE DECIMAL: .005 UNLESS OTHERWISE SPECIFIED ANY CHANGES TO THIS DRAWING SHOULD BE MADE TO THE PART MODEL SO THAT THE CHANGES ARE MADE PARAMETRICALLY		PART NAME SEE CHART SHEET 2	
		APPROVALS	
THE INFORMATION ON THIS DRAWING IS CONFIDENTIAL AND IS THE SOLE PROPERTY OF CURRIER PLASTICS. NEITHER THIS DOCUMENT, NOR ANY INFORMATION DISCLOSED HEREIN SHALL BE REPRODUCED OR TRANSFERRED TO OTHER DOCUMENTS OR TO BE USED FOR MANUFACTURING PURPOSES OR DISCLOSED TO OTHERS FOR ANY PURPOSE EXCEPT AS SPECIFICALLY AUTHORIZED IN WRITING BY CURRIER PLASTICS		DESIGNED & DETAILED BY:	DATE
		VP OF N.P.D.	
CAD REFERENCE # IM0121		PROJECT ENG MGR	
LIFECYCLE: RELEASE FOR PRODUCTION		QA MGR	
SHEET SIZE C	VIEW SCALE 1:1	SHEET 2 OF 2	
PART # SEE CHART SHEET 2		PROCESS: IM	REV. 2-02
WEIGHT: 1.8grams		MATERIAL: PP	
CUSTOM DESIGN / INJECTION MOLDING / BLOW MOLDING 